

KICKER | PXi50.2

Amplified Controller for iPod® / iPhone®

ELECTRONICS LIMITED WARRANTY

When purchased from an Authorized KICKER Dealer, KICKER warrants this product to be free from defects in material and workmanship under normal use for a period of TWO (2) YEARS from date of original purchase with receipt. If this product is identified as "Refurbished" or "B Goods", the warranty is limited to a period of THREE (3) MONTHS from the date of original purchase. In all cases you must have the original receipt. Should service be necessary under this warranty for any reason due to manufacturing defect or malfunction during the warranty period, KICKER will repair or replace (at its discretion) the defective merchandise with equivalent merchandise. Warranty replacements may have cosmetic scratches and blemishes. Discontinued products may be replaced with more current equivalent products. This warranty is valid only for the original purchaser and is not extended to owners of the product subsequent to the original purchaser. Any applicable implied warranties are limited in duration to a period of the express warranty as provided herein beginning with the date of the original purchase at retail, and no warranties, whether express or implied, shall apply to this product thereafter. Some states do not allow limitations on implied warranties; therefore, these exclusions may not apply to you. This warranty gives you specific legal rights; however you may have other rights that vary from state to state.

WHAT TO DO IF YOU NEED WARRANTY OR SERVICE:

Defective merchandise should be returned to your local Authorized Stillwater Designs (KICKER) Dealer for warranty service. Assistance in locating an Authorized Dealer can be found at www.kicker.com or by contacting Stillwater Designs directly. You can confirm that a dealer is authorized by asking to see a current authorized dealer window decal.

If it becomes necessary for you to return defective merchandise directly to Stillwater Designs (KICKER), call the KICKER Customer Service Department at (405) 624-8510 for a Return Merchandise Authorization (RMA) number. Package only the defective items in a package that will prevent shipping damage, and return to:

Stillwater Designs, 3100 North Husband St, Stillwater, OK 74075

The RMA number must be clearly marked on the outside of the package. Please return only defective components. The return of functioning items increases your return freight charges. Non-defective items will be returned freight collect to you. For example, if a subwoofer is defective, only return the defective subwoofer, not the entire enclosure. Include a copy of the original receipt with the purchase date clearly visible, and a "proof-of-purchase" statement listing the Customer's name, Dealer's name and invoice number, and product purchased. Warranty expiration on items without proof-of-purchase will be determined from the type of sale and manufacturing date code. Freight must be prepaid; items sent freight-collect, or COD, will be refused.

WHAT IS NOT COVERED?

This warranty is valid only if the product is purchased from an Authorized KICKER Dealer and used for the purpose for which it was designed. It does not cover:

- o Damage due to improper installation and/or subsequent damage to other components.
- o Damage caused by exposure to moisture, excessive heat, chemical cleaners, and/or UV radiation.
- o Damage through negligence, misuse, accident or abuse.
- o Repeated returns for the same damage may be considered abuse.
- o Any cost or expense related to the removal or reinstallation of product.
- o Speakers damaged due to amplifier clipping or distortion.
- o Items previously repaired or modified by any unauthorized repair facility.
- o Return shipping on non-defective items.
- o Products with tampered or missing barcode labels.
- o Products returned without a Return Merchandise Authorization (RMA) number.
- o Freight Damage.
- o The cost of shipping product to KICKER.
- o Service performed by anyone other than KICKER.

HOW LONG WILL IT TAKE?

KICKER strives to maintain a goal of one week turnaround for all electronics (amplifiers, crossovers, equalizers, etc.) returns. Delays may be incurred if lack of replacement inventory or parts is encountered. Failure to follow these steps may void your warranty. Any questions can be directed to the KICKER Customer Service Department at (405) 624-8510. Contact your International KICKER dealer or distributor concerning specific procedures for your country's warranty policies.

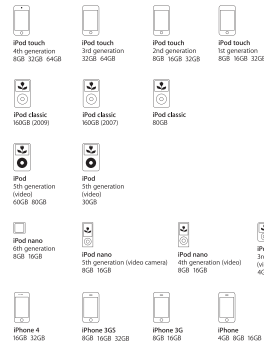

Flush mounting the remote (requires custom installation)

Montaje del mando a distancia al ras (requiere instalación a medida)

Einbaumontage der Fernbedienung (maßgeschneiderte Montage erforderlich)

Installation encastrée de la commande à distance (nécessite une installation spécifique)

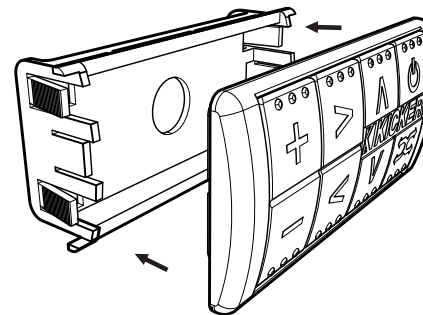

*Remote may also be mounted with adhesive. Be careful not to drill into wiring or vehicle mechanisms. You are solely responsible for securely mounting the amplifier and remote.

*El mando a distancia también puede ser instalado con un adhesivo. Tenga cuidado de no taladrar el cableado o los mecanismos del vehículo. Usted es el único responsable por la instalación segura del amplificador y del mando a distancia.

*Die Fernbedienung kann auch mit Klebstoff angeklebt werden. Geben Sie acht, dass Sie nicht die Kabel oder Fahrzeugmechanik anbohren. Sie allein sind für die sichere Anbringung des Verstärkers und der Fernbedienung verantwortlich.

*Le dispositif de commande à distance peut également être installé avec du ruban adhésif. Veillez à ne pas percer le câblage ou les mécanismes du véhicule. Vous êtes entièrement responsable de l'installation sécurisée de l'amplificateur et du dispositif de commande à distance.



Mount the module behind the fairing, underneath the seat, or in another secure location isolated from weather.

Instale el módulo detrás del carenado, debajo del asiento o en otra ubicación segura, aislado de las inclemencias del clima.

Montieren Sie das Modul hinter der Verkleidung, unter dem Sitz oder an einer anderen sicheren, witterungsgeschützten Stelle.

Installez le module derrière capot, sous siège ou à un autre emplacement sécurisé, protégé des intempéries.



Bar mounting the remote (left or right)

Montaje del mando a distancia en manillar (izquierda o derecha)

Anbringung der Fernbedienung an Lenkstange (links oder rechts)

Installation de la commande à distance sur un guidon (gauche ou à droite)

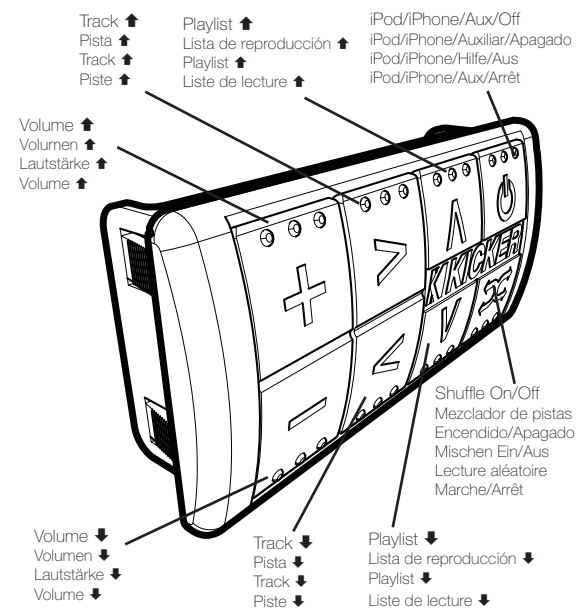
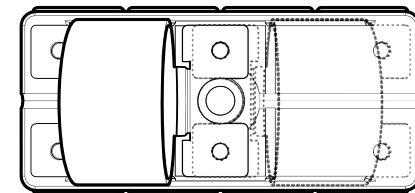

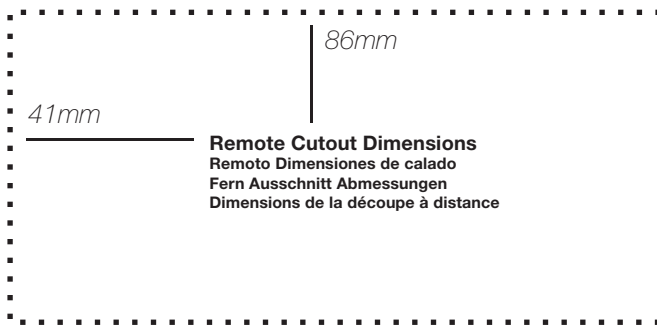

Mounting depth - 18mm
Profundidad de montaje - 18mm
Montagetiefe - 18mm
Profondeur de montage - 18mm



Connect the PXi50.2 to your vehicle's source unit and to the PXi Remote. Install 10A fuse to +12V Constant.

Conecte el PXi50.2 a la unidad fuente de su vehículo y al mando a distancia del PXi. Instalar fusible de 10A a +12V Constante.

Verbinden Sie PXi50.2 mit der Stromquelle in Ihrem Fahrzeug und der PXi-Fernbedienung. Installieren 10A-Sicherung bis +12 V Konstante.

Branchez le PXi50.2 à l'alimentation de votre véhicule et au dispositif de lecture à distance PXi. Installez le fusible 10A à +12 V Constant.

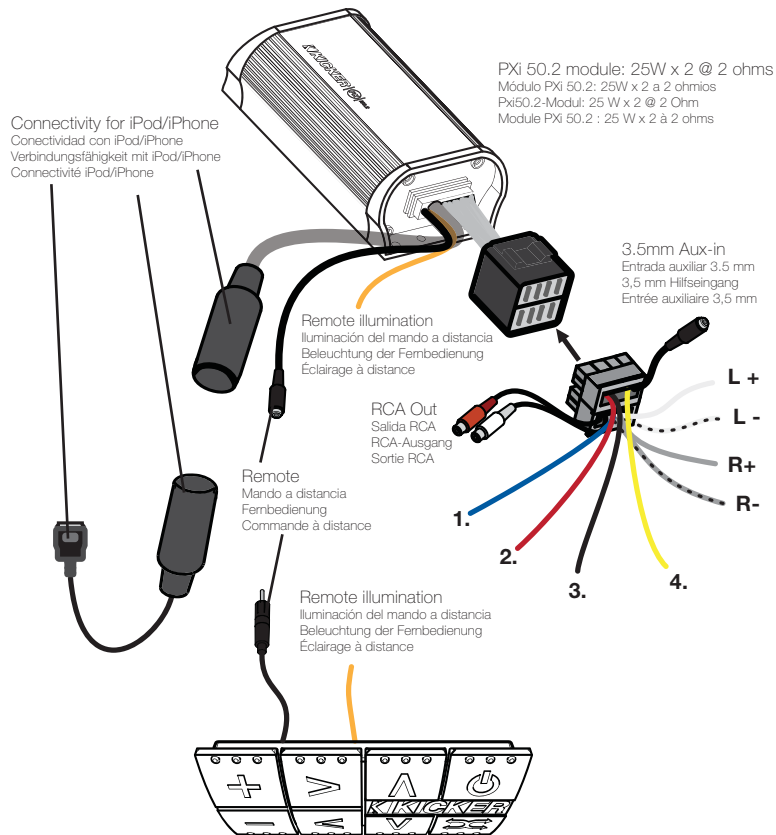

1. Remote out
 Salida mando a distancia
 Fernbedienung Aus
 Sortie de commande à distance

2. +12V Ignition
 Encendido +12V
 +12V-Zündung
 Allumage + 12 V

3. Ground
 Tierra
 Erdung
 Masse

4. +12V Constant
 Constante +12V
 +12V-Konstante
 Constante + 12 V

INTERNATIONAL WARRANTY

Contact your International KICKER dealer or distributor concerning specific procedures for your country's warranty policies.

WARNING: KICKER products are capable of producing sound levels that can permanently damage your hearing! Turning up a system to a level that has audible distortion is more damaging to your ears than listening to an undistorted system at the same volume level. The threshold of pain is always an indicator that the sound level is too loud and may permanently damage your hearing. Please use common sense when controlling volume.

GARANTÍA INTERNACIONAL

Versión Español

Comuníquese con su concesionario o distribuidor KICKER internacional para obtener información sobre procedimientos específicos relacionados con las normas de garantía de su país.

ADVERTENCIA: Los excitadores KICKER son capaces de producir niveles de sonido que pueden dañar permanentemente el oído. Subir el volumen del sistema hasta un nivel que produzca distorsión es más dañino para el oído que escuchar un sistema sin distorsión al mismo volumen. El dolor es siempre una indicación de que el sonido es muy fuerte y que puede dañar permanentemente el oído. Sea precavido cuando controle el volumen.

La frase "combustible para vivir la vida Livin' Loud™ a todo volumen" se refiere al entusiasmo por la vida que la marca KICKER de estéreos de automóvil representa y a la recomendación a nuestros clientes de que vivan lo mejor posible ("a todo volumen") en todo sentido. La línea de altavoces y amplificadores KICKER es la mejor del mercado de audio de automóviles y por lo tanto representa el "combustible" para vivir a todo volumen en el área de "estéreos de automóvil" de la vida de nuestros clientes. Recomendamos a todos nuestros clientes que obedezcan todas las reglas y reglamentos locales sobre ruido en cuanto a los niveles legales y apropiados de audición fuera del vehículo.

INTERNATIONALE GARANTIE

Deutsche Version

Nehmen Sie mit Ihren internationalen KICKER-Fachhändler oder Vertrieb Kontakt auf, um Details über die Garantieleistungen in Ihrem Land zu erfahren.

WARNUNG: KICKER-Treiber können einen Schallpegel erzeugen, der zu permanenten Gehörschäden führen kann! Wenn Sie ein System auf einen Pegel stellen, der hörbare Verzerrungen erzeugt, schadet das Ihren Ohren mehr, als ein nicht verzerrtes System auf dem gleichen Lautstärkepegel. Die Schmerzschwelle ist immer eine Anzeige dafür, dass der Schallpegel zu laut ist und zu permanenten Gehörschäden führen kann. Seien Sie bei der Lautstärkeinstellung bitte vernünftig!

Der Slogan "Treibstoff für Livin' Loud" bezieht sich auf die mit den KICKER-Autostereosystemen assoziierte Lebensfreude und die Tatsache, dass wir unsere Kunden ermutigen, in allen Aspekten ihres Lebens nach dem Besten ("Livin' Loud") zu streben. Die Lautsprecher und Verstärker von KICKER sind auf dem Markt für Auto-Soundsysteme führend und stellen somit den "Treibstoff" für das Autostereoerlebnis unserer Kunden dar. Wir empfehlen allen unseren Kunden, sich bezüglich der zugelassenen und passenden Lautstärkepegel außerhalb des Autos an die örtlichen Lärmvorschriften zu halten.

GARANTIE INTERNATIONALE

Versión Française

Pour connaître les procédures propres à la politique de garantie de votre pays, contactez votre revendeur ou distributeur International KICKER.

AVERTISSEMENT: Les haut-parleurs KICKER ont la capacité de produire des niveaux sonores pouvant endommager l'ouïe de façon irréversible ! L'augmentation du volume d'un système jusqu'à un niveau présentant une distorsion audible endommage davantage l'ouïe que l'écoute d'un système sans distorsion au même volume. Le seuil de la douleur est toujours le signe que le niveau sonore est trop élevé et risque d'endommager l'ouïe de façon irréversible. Réglez le volume en faisant preuve de bon sens!

L'expression "carburant pour vivre plein pot" fait référence au dynamisme de la marque KICKER d'équipements audio pour véhicules et a pour but d'encourager nos clients à faire le maximum ("vivre plein pot") dans tous les aspects de leur vie. Les haut-parleurs et amplificateurs KICKER sont les meilleurs dans le domaine des équipements audio et représentent donc pour nos clients le "carburant pour vivre plein pot" dans l'aspect "installation audio de véhicule" de leur vie. Nous encourageons tous nos clients à respecter toutes les lois et réglementations locales relatives aux niveaux sonores acceptables à l'extérieur des véhicules.



"Made for iPod," and "Made for iPhone" mean that an electronic accessory has been designed to connect specifically to iPod or iPhone, respectively, and has been certified by the developer to meet Apple performance standards. Apple is not responsible for the operation of this device or its compliance with safety and regulatory standards. Please note that the use of this accessory with iPod or iPhone may affect wireless performance.