

KICKER®

*Select Language
Owner's Manual*

*Seleccione el Idioma
Manual del
Propietario*

*Choisir la Langue
Manuel d'utilisation*

*Sprache Auswählen
Benutzerhandbuch*

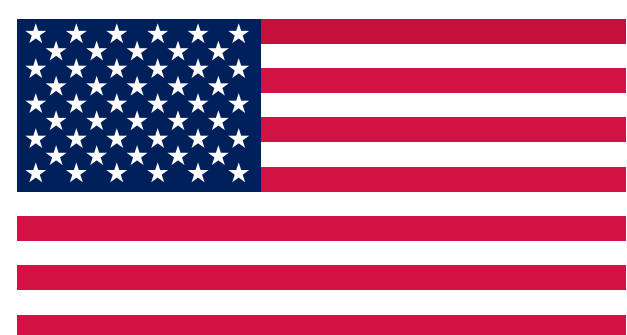

KICKER VXA-Series

Mono Amplifiers

Amplificadores Mono de la Serie VXA

Amplificateurs Mono Série VXA

Mono-Verstärker der VXA-Serie

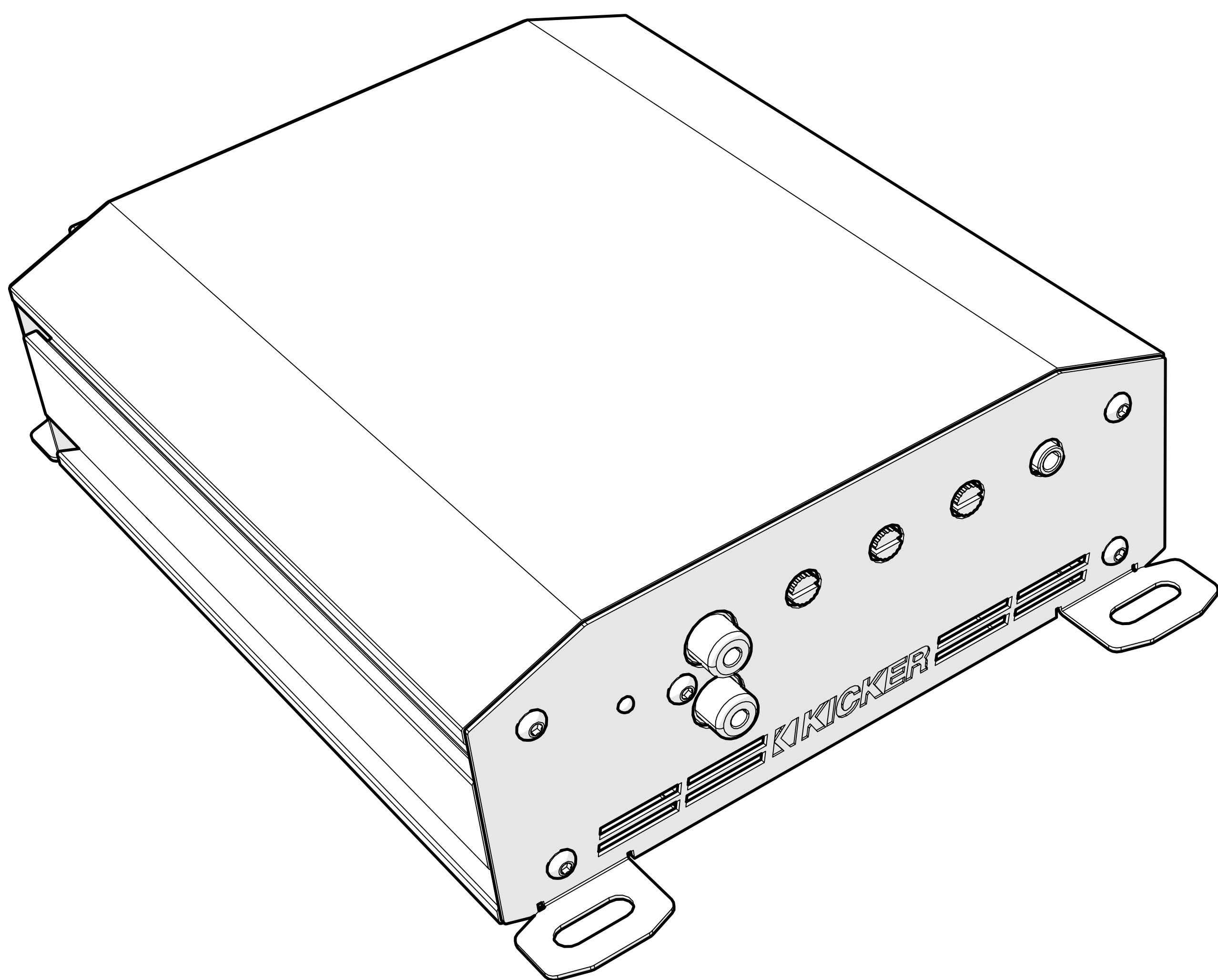

VXA350.1 | VXA700.1 | VXA1000.1

Contents

Overview	3
Specifications	4
Installation	5
Mounting.....	5
Power Wiring.....	6
Subwoofer Wiring	10
Operation	11
Remote Bass Surface Mount	15
Remote Bass Flush Mount...	16
Troubleshooting	18
Warranty	19
International Warranty Garantía Garantie	

Overview

IMPORTANT SAFETY WARNING

PROLONGED CONTINUOUS OPERATION OF AN AMPLIFIER, SPEAKER, OR SUBWOOFER IN A DISTORTED, CLIPPED OR OVER-POWERED MANNER CAN CAUSE YOUR AUDIO SYSTEM TO OVERHEAT, POSSIBLY CATCHING FIRE AND RESULTING IN SERIOUS DAMAGE TO YOUR COMPONENTS AND/OR VEHICLE. AMPLIFIERS REQUIRE UP TO 4 INCHES (10CM) OPEN VENTILATION. SUBWOOFERS SHOULD BE MOUNTED WITH AT LEAST 1 INCH (2.5CM) CLEARANCE BETWEEN THE FRONT OF THE SPEAKER AND ANY SURFACE. KICKER PRODUCTS ARE CAPABLE OF PRODUCING SOUND LEVELS THAT CAN PERMANENTLY DAMAGE YOUR HEARING! TURNING UP A SYSTEM TO A LEVEL THAT HAS AUDIBLE DISTORTION IS MORE DAMAGING TO YOUR EARS THAN LISTENING TO AN UNDISTORTED SYSTEM AT THE SAME VOLUME LEVEL. THE THRESHOLD OF PAIN IS ALWAYS AN INDICATOR THAT THE SOUND LEVEL IS TOO LOUD AND MAY PERMANENTLY DAMAGE YOUR HEARING. PLEASE USE COMMON SENSE WHEN CONTROLLING VOLUME.

The VXA Amplifiers from KICKER are engineered to deliver clean, powerful music in nearly any vehicle without replacing your factory radio or adding a line-output converter. Thanks to KICKER's FIT™ (Fail-Safe Integration Technology), these amps provide superior noise rejection even when paired with premium OEM systems.

The efficient Class-D design features variable 12 dB crossovers for precise speaker matching, KickEQ™ variable bass boost, and a 24 dB subsonic filter on mono models. Mono channels are stable down to 1 ohm for maximum bass impact, and include the VXARC remote bass knob for on-the-fly control. Built tough with premium materials and KICKER's signature durability, the VXA series is the ideal power solution for your speakers and subwoofers.

Use with any combination of KICKER products, including KICKER subwoofers and full-range speakers.

VXA Mono

Specifications

Model:	VXA350.1	VXA700.1	VXA1000.1
Dynamic Power [Watts]	500W	900W	1400W
RMS Power Output [Watts]			
@ 14.4V, 4Ω mono, ≤ 1% THD+N	125W X 1	250W X 1	400W X 1
@ 14.4V, 2Ω mono, ≤ 1% THD+N	250W X 1	500W X 1	750W X 1
@ 14.4V, 1Ω mono, ≤ 1% THD+N	350W X 1	700W X 1	1000W X 1
Length [in, cm]	8 7/32, 20.9	8 15/16, 22.7	9 1/2, 24.2
Specifications Common to All Models			
Height [in, cm]	2 3/16, 5.6		
Width [in, cm]	5 29/32, 15		
Frequency Response [Hz]	10Hz–200Hz		
Selectable Electronic Crossover	Variable Lo-pass 50Hz–200Hz, 12dB/octave		
Subsonic Filter	Fixed 15Hz, 24dB/Octave		
KickEQ™ Bass Boost	Variable 0-6dB @ 40Hz		
Remote Bass Control	Yes (Included)		
Signal-to-Noise Ratio [dB]	>95dB, a-weighted, re: rated power		
Signal-to-Noise Ratio [dB]	>-75dB CEA-2006B (ref: 1W, A-weighted)	>-70B CEA- 2006B (ref: 1W, A-weighted)	
Input Sensitivity	125mV–10V		

Note: All specifications and performance figures are subject to change. Please visit www.kicker.com for the most current information. To get the best performance from your new KICKER amplifier, we recommend using genuine KICKER speakers, accessories and wiring.

Installation

Mounting

Choose a structurally sound location to mount your KICKER amplifier. Make sure there are no items behind the area where the screws will be driven. Choose a location that allows at least 4" (10cm) of open ventilation for the amplifier. Drill four holes using a 7/64" (3mm) bit and use the supplied #8 screws to mount the amplifier.

Pro Tip: All that's left is a [KICKER Subwoofer](#), and a [few cables](#), and you'll have an audio upgrade that will dominate any factory system! KICKER amplifiers make it easy to upgrade to solid bass with your existing or stock source unit. Ask your dealer about KICKER upgrades.

Power Wiring

[Click Here for Amplifier Install Kits](#)

Model	External Fuse (sold separately)	Power/Ground Wire	KICKER Wiring Kit
VXA350.1	1 x 40 Ampere	8 Gauge	PK8, CK8, VK8
VXA700.1	1 x 80 Ampere	6 Gauge	VK6
VXA1000.1	1 x 100 Ampere	4 Gauge	PK4, CK4, PKD4

Disconnect the vehicle's battery negative terminal to avoid an electrical short.

A secure, low-resistance ground connection is essential for proper amplifier performance and noise suppression. Connect the ground wire to the amplifier first. Make the ground wire as short as possible, 24" (60 cm) or less, and connect it to a clean, paint- and corrosion-free, solid metal area of the vehicle's chassis. Scrape away all paint, rust, or coatings at the contact point and use a star washer or self-tapping screw to ensure a tight connection.

Keep audio signal cables away from factory wiring harnesses and other power wiring. When crossing is unavoidable, cross signal cables and power wires at a 90° angle to minimize electromagnetic interference.

The VXA-series are capable of receiving both Low-level and Hi-level signals with the RCA inputs on the front panel of the amplifier.

Battery Current Sensors: Many modern vehicles are equipped with a battery current sensor (Intelligent Battery Sensor / IBS or Hall-effect sensor) located at or near the negative battery terminal. This sensor allows the vehicle's charging system to accurately monitor total current flow.

Adding an additional ground wire directly between the battery's negative post and the vehicle chassis can bypass this sensor. This may cause inaccurate battery monitoring, illumination of a battery warning light, reduced alternator charging, or other charging system issues.

If you are unsure whether your vehicle has this sensor or how to identify the correct grounding points, have the installation performed by a professional or consult the vehicle manufacturer's service information.

Fuse installation should be as close as possible to the battery, and no further than 18" (45cm) of the battery, and in-line with the power cable, which is connected to your VXA Amplifier. Make sure the power wire is routed so that it will not be damaged, crimped, or shorted. If you ever need to remove the amplifier from the vehicle after it has been installed, the ground wire should be the last wire disconnected from the amplifier; just the opposite as when you installed it.

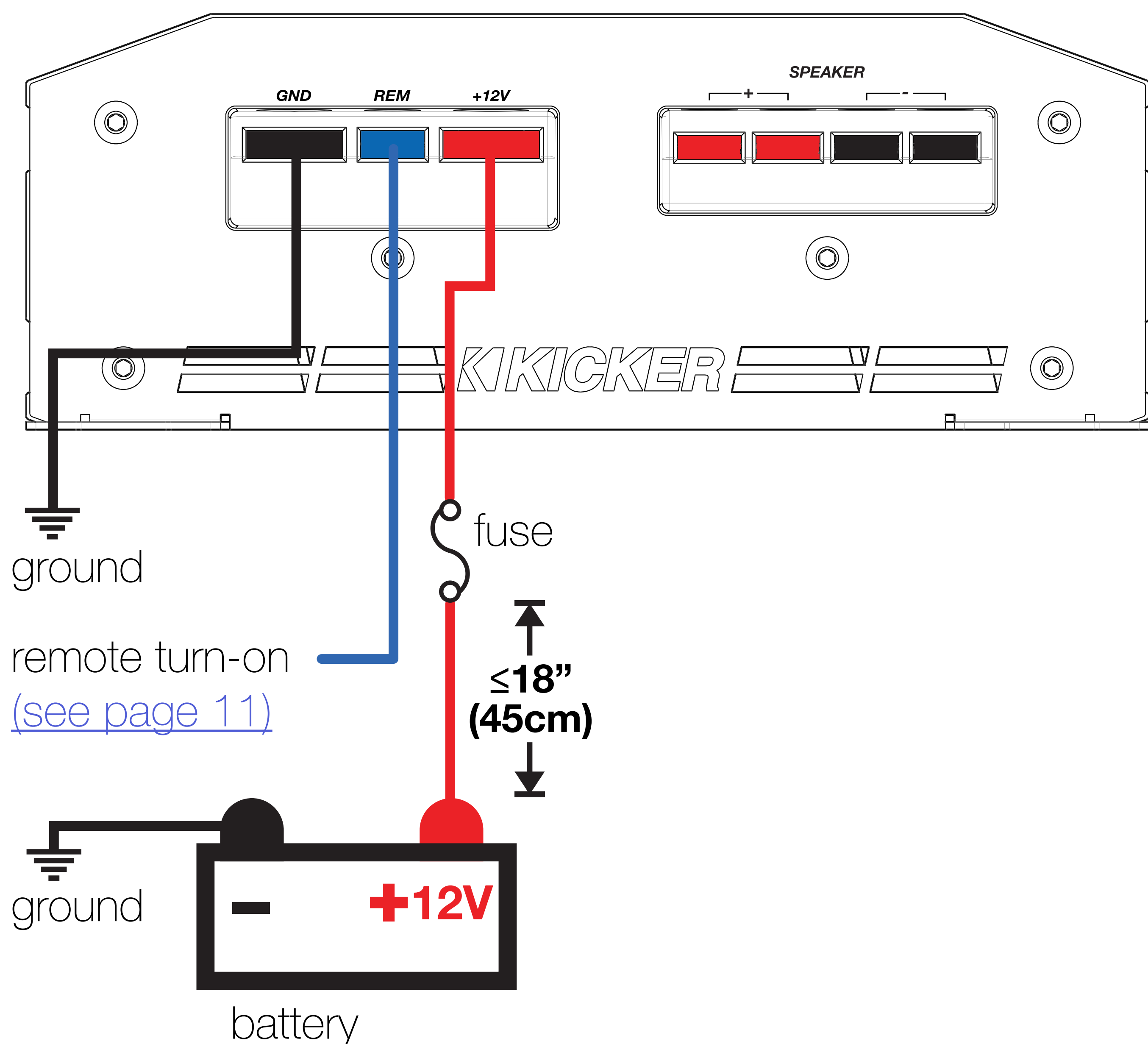

For multiple amplifier installations where distribution blocks are used, each amplifier should have its proper-rated fuse, or breaker, installed between the amplifier and the distribution block within eighteen inches of the block, or on the distribution block if it provides for fusing. The primary power wire should also be fused between the battery and distribution block, within eighteen inches of the battery's positive terminal, with a fuse or breaker rated at least to the sum of the individual amplifier's fuse values, but doesn't exceed the capacity of your wiring.

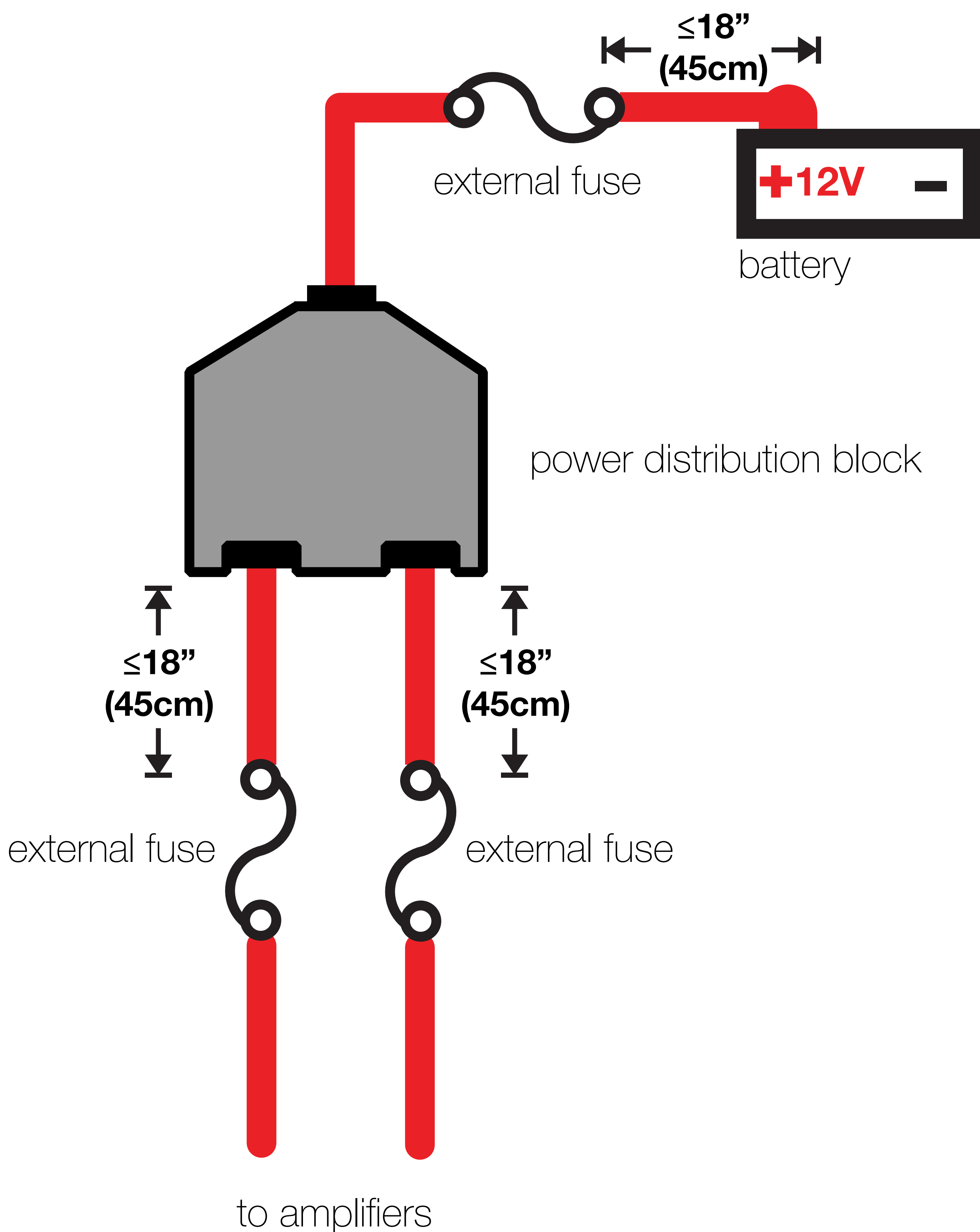

Subwoofer Wiring

Single Dual Voice Coil

L7 Subwoofer wired in parallel.

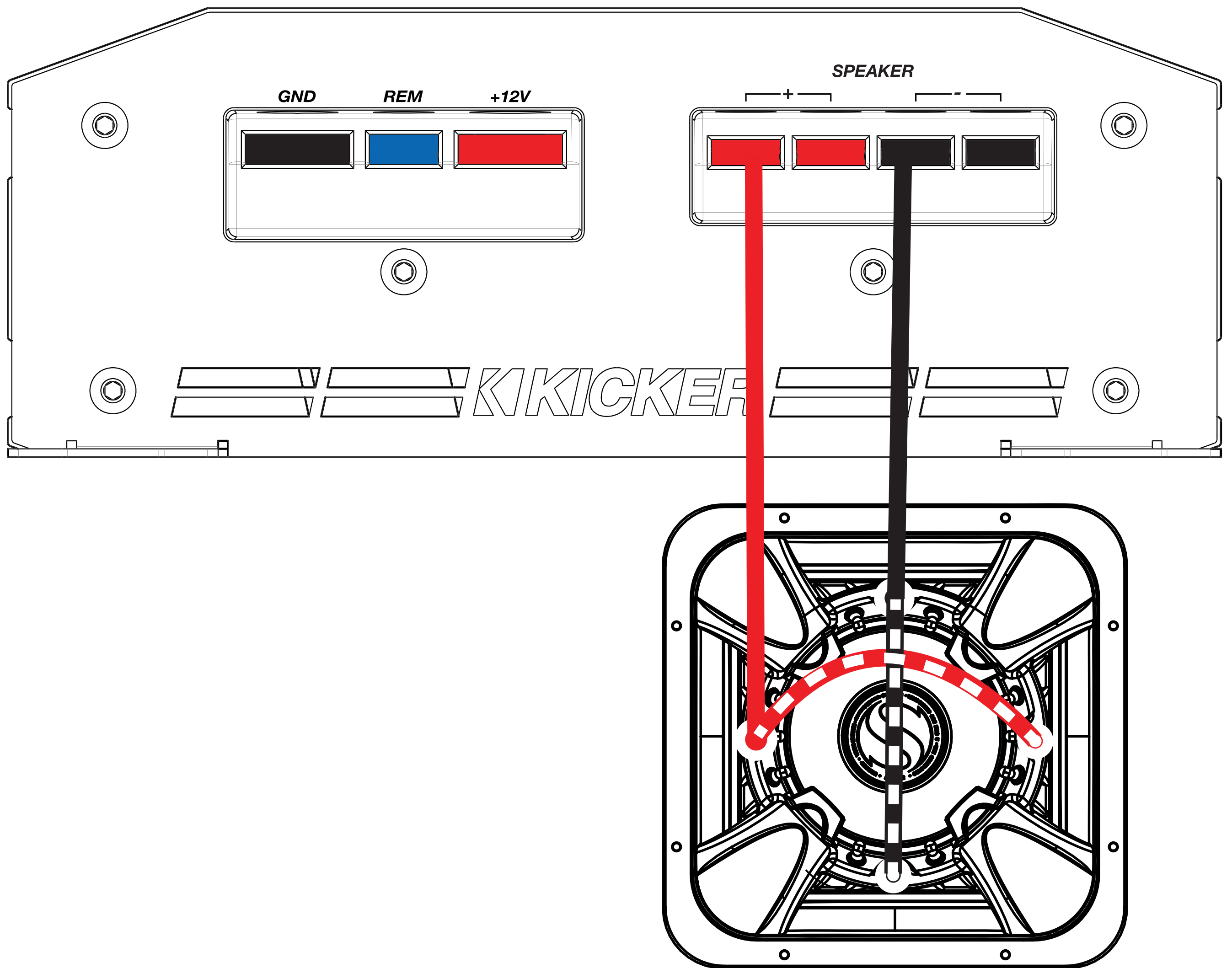

Two Dual Voice Coil L7 Subwoofers wired in Series/Parallel

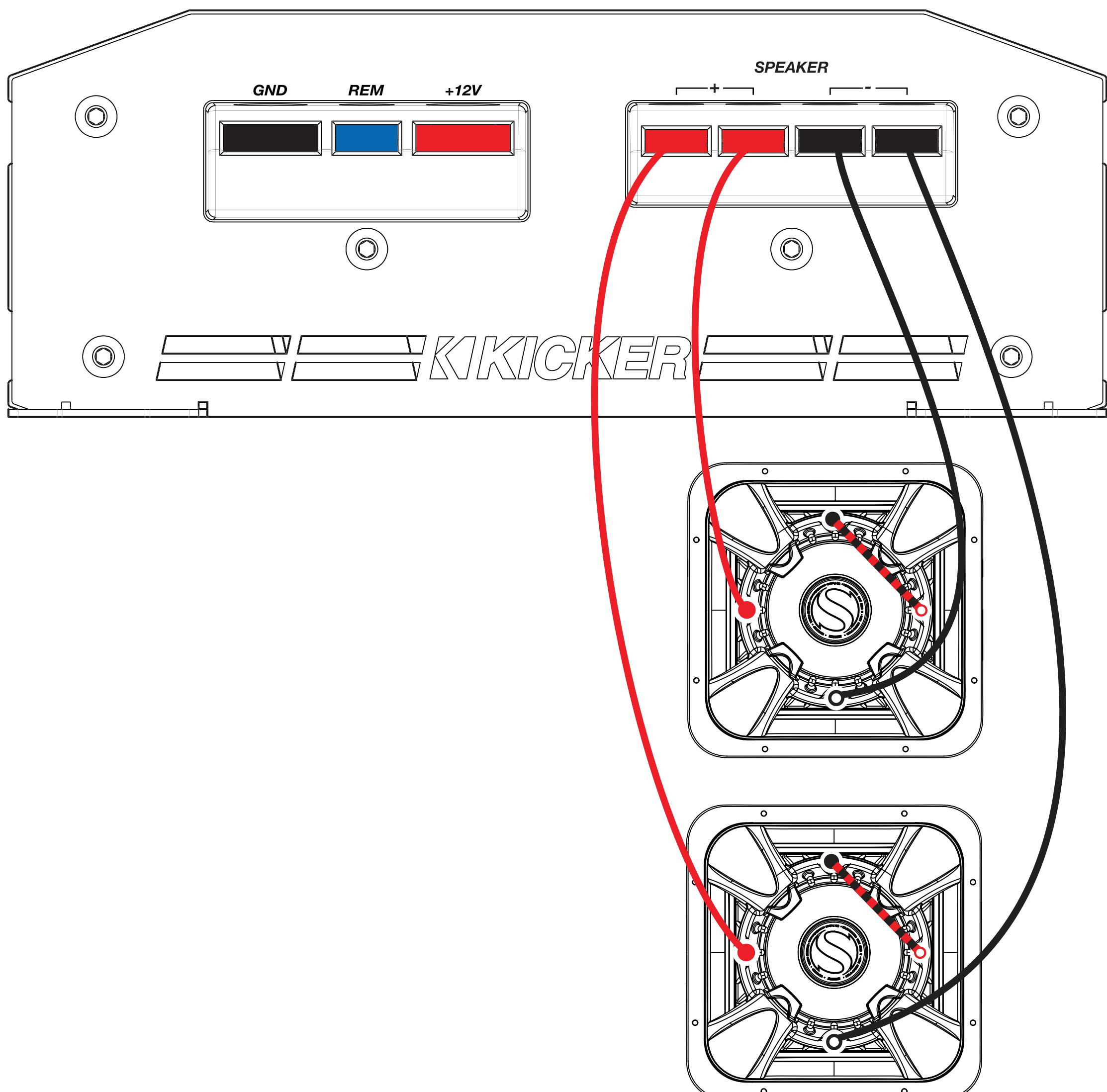

Operation

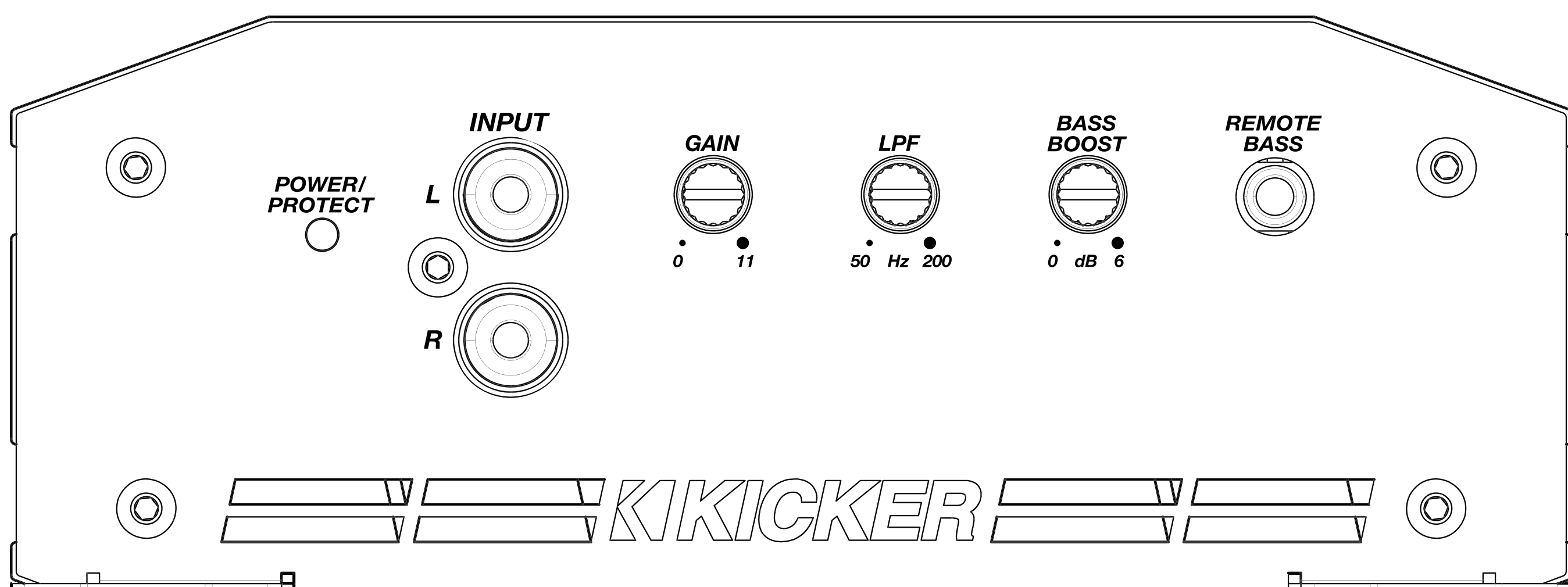

Automatic Turn-On: The VXA-series offers two different automatic turn-on modes; +12V and DC Offset.

- Remote Turn-On: Run 18 gauge wire from the Remote Turn-On Lead on your source unit to the REM terminal on the VXA amplifier's end panel.
- DC Offset Turn-On: The DC Offset mode detects a >2.5V DC from the Hi-Level speaker output of the source unit when it has been turned on.

INPUT GAIN: The input gain control is not a volume control. It adjusts the amplifier's input sensitivity to match the output signal level from the source unit. When set correctly, the amplifier can produce its full rated power cleanly. Setting the gain too high will cause distorted output and can result in damage to, or premature failure of, your speakers.

To set the gain using the preferred method with a voltmeter or oscilloscope, first turn the amplifier off and disconnect all speakers from it. Turn the gain control fully counterclockwise to its minimum setting and set all crossovers to their least aggressive position. If a remote bass control is connected to the amplifier, turn it fully clockwise. Set all EQ, tone controls, DSP settings, fader, balance, and seating position controls on the source unit to flat, center, or off. Turn the amplifier on.

Play a 0 dB sine wave test tone through the source unit and slowly raise the volume until the signal just begins to clip on an oscilloscope, then reduce the volume by one step. This is the maximum unclipped output level of the source unit. Free test tones are available at [KICKER.com under the "Support" tab](https://www.kicker.com/support). Use the 50 Hz tone when

setting subwoofer channels and the 1 kHz tone for full-range channels.

Set your voltmeter or oscilloscope to measure AC voltage and place the probes on the amplifier's speaker output terminals. With the test tone playing, slowly turn the gain control clockwise while watching the voltage rise. Stop increasing the gain when the voltmeter reaches the target AC voltage shown on the [power chart at KICKER.com](#) for your amplifier model and speaker impedance, or when the waveform begins to square off on an oscilloscope.

Turn the amplifier off, reconnect the speakers, and return the crossovers and remote bass control to your normal settings. The gain is now properly set for maximum clean output from the amplifier.

Note: If you increase the max volume from the source unit, change EQ or DSP settings, or use the bass boost control on the amplifier, distortion could be introduced and the gain-setting procedure will need to be repeated.

KICKEQ Bass Boost: The variable bass boost control on the side of the amplifier is designed to give you increased output, 0–6dB, at 40Hz. The setting for this control is subjective. If you turn it up, you must readjust the input gain control to avoid clipping the amplifier.

LPF (Low-Pass Crossover): The variable low-pass crossover on the side of the amplifier allows you to adjust the lo-pass crossover frequency from 50Hz–200Hz (12dB/octave).

REMOTE BASS: With the optional VXARC remote bass level control, you have the ability to control the output level of the amplifier remotely. To surface-mount the remote bass level control, simply screw the remote to the chosen location, then run the cable from the controller to the “Remote Bass” jack on the amplifier panel. Once the amplifier’s gain has been properly set, this bass level control allows you to decrease or increase the subwoofer level up to the point of maximum, unclipped (non-distorted) output.

Remote Bass Surface Mount

Surface mount the VXARC remote using the supplied screws.

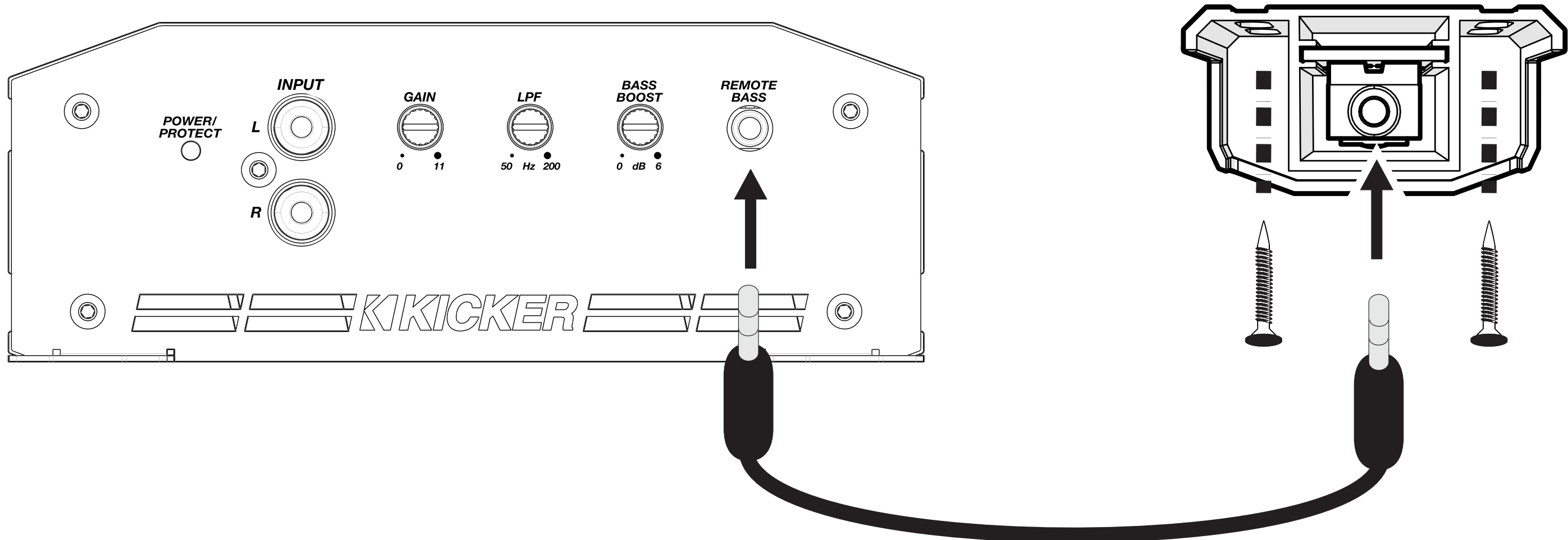

Remote Bass Flush Mount

Drill a 9/32" (7.5mm) hole in the surface behind which you will be mounting the VXARC remote knob.

Remove the VXARC knob.

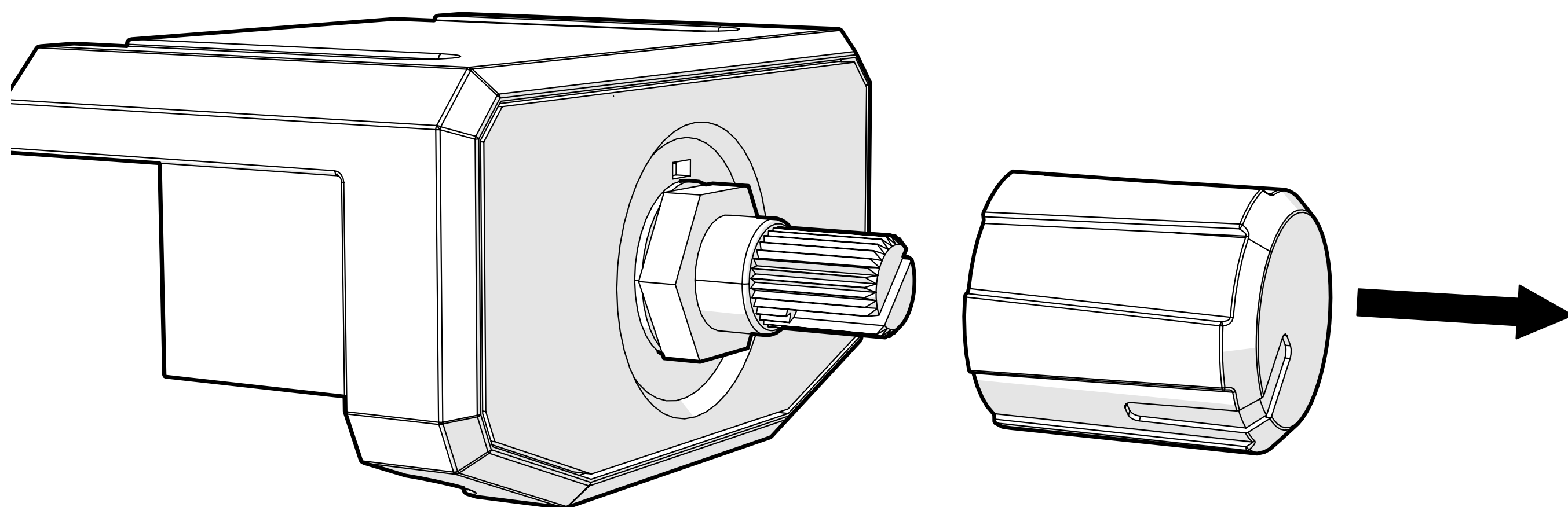

Remove the 10mm nut and washer from the potentiometer.

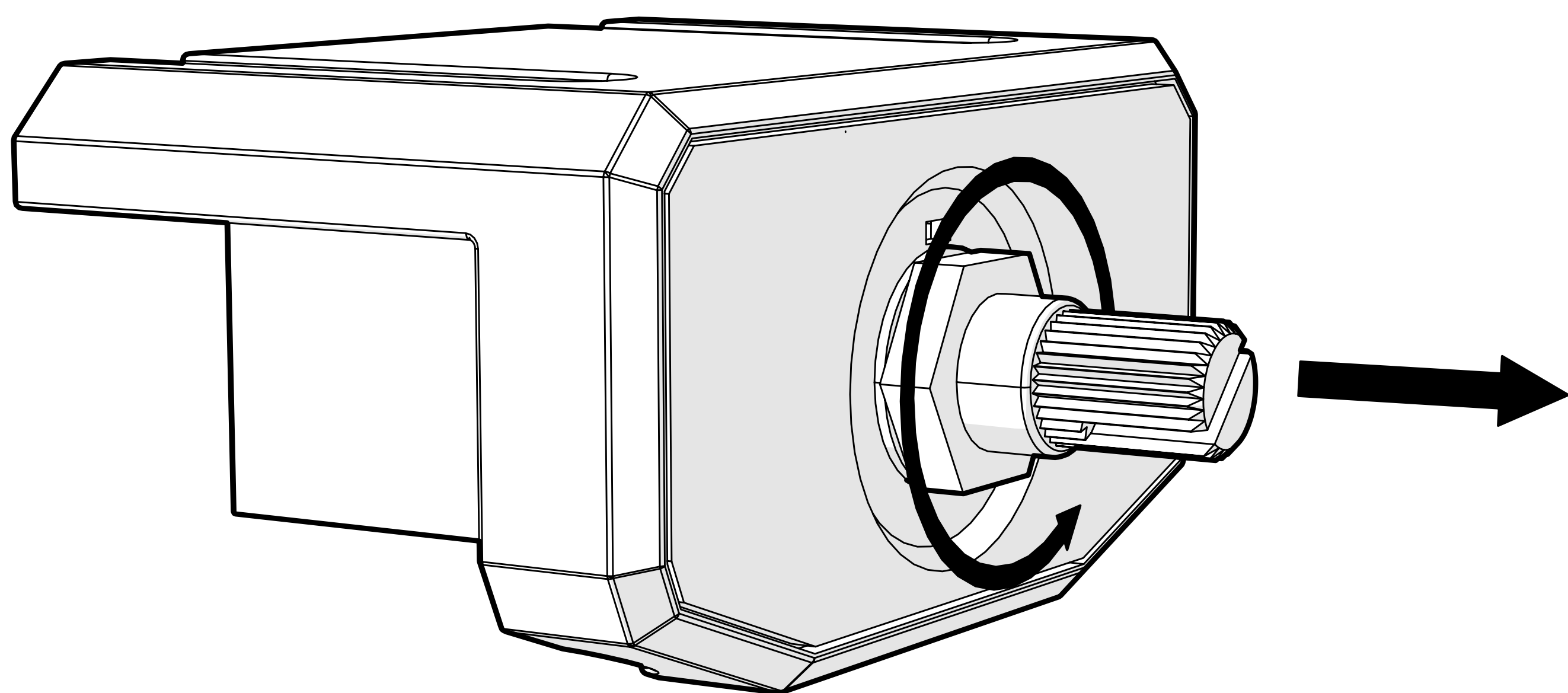

Slide out the VXARC control board.

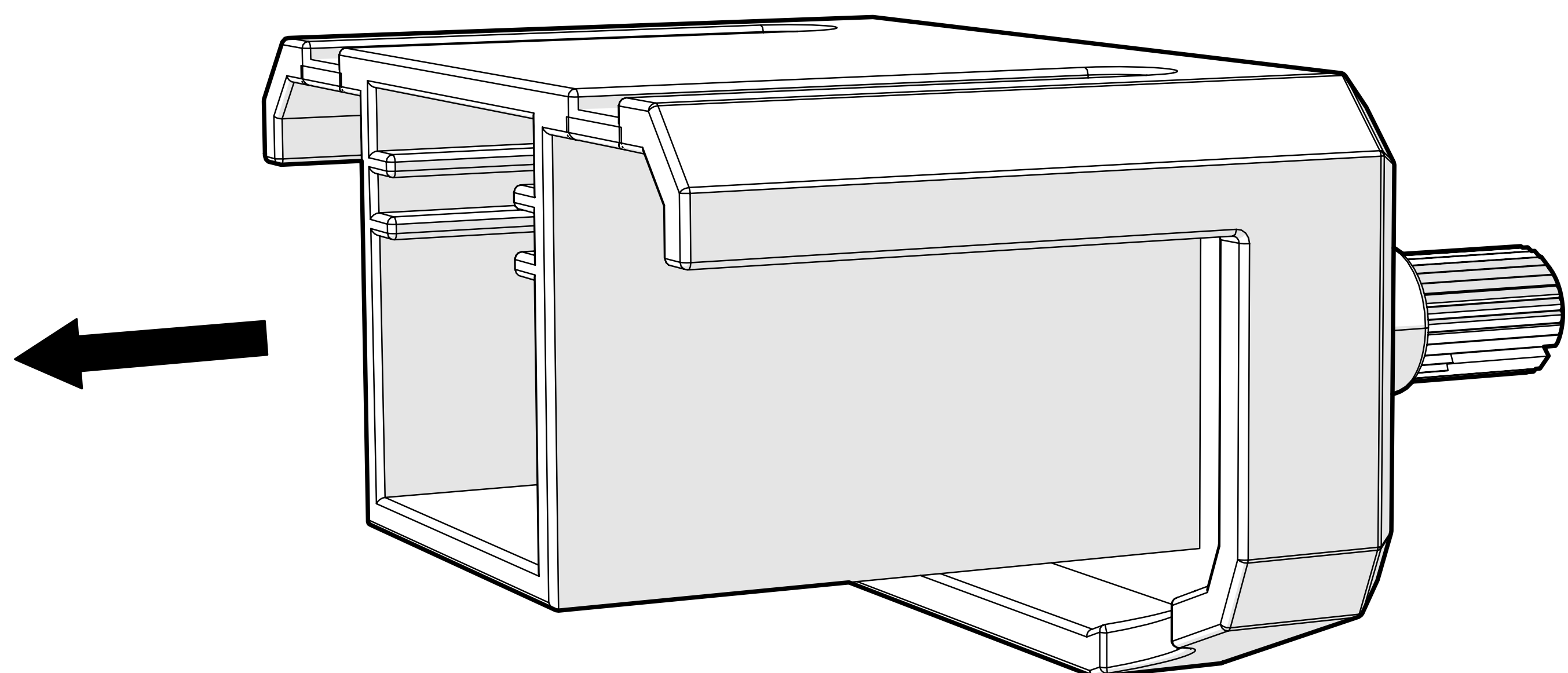

Place the potentiometer through the hole cutout and secure it using the 10mm nut and washer.

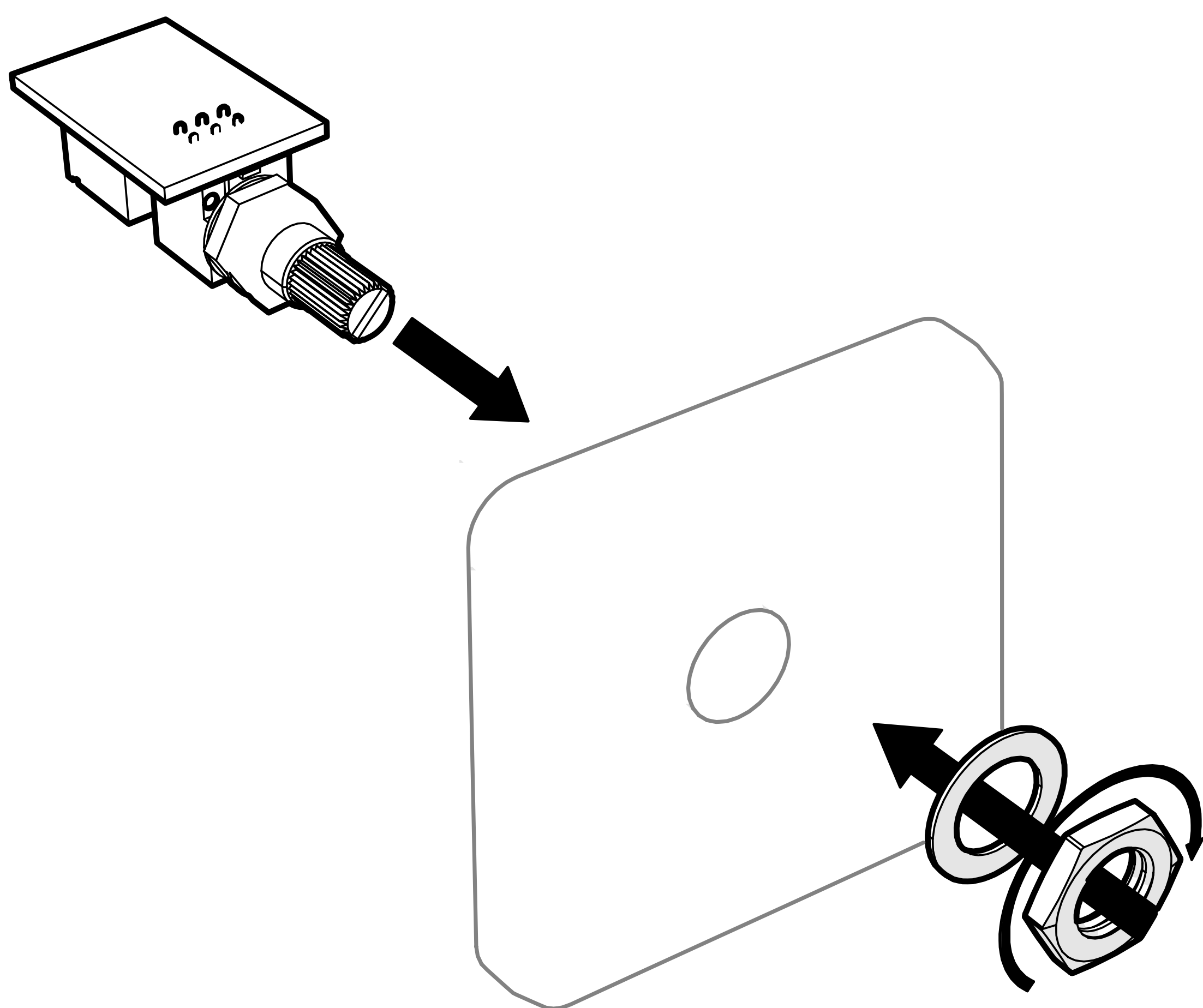

Reattach the VXARC knob to the potentiometer.

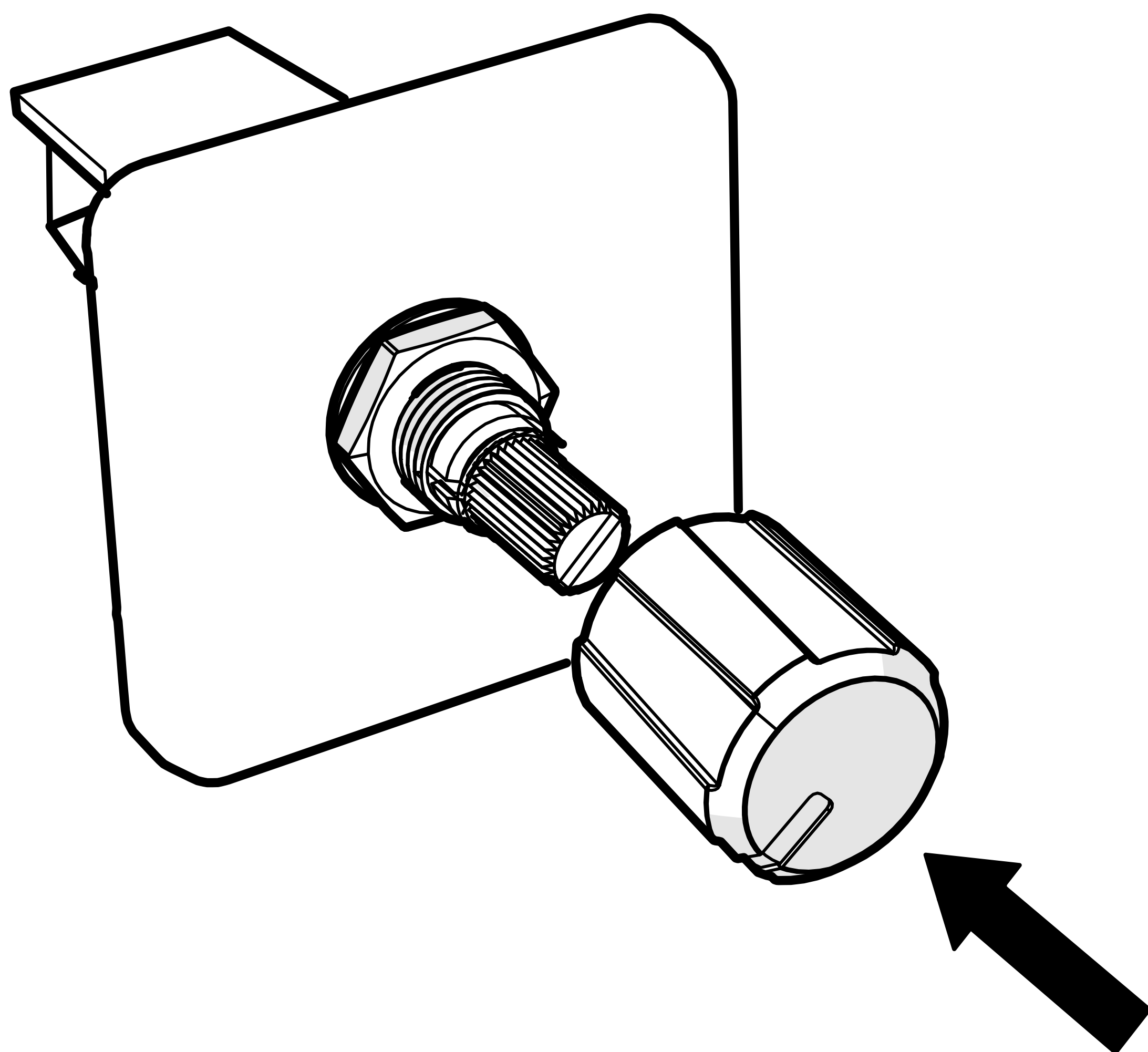

Troubleshooting

If your amplifier does not appear to be working, check the obvious things first such as blown fuses, poor or incorrect wiring connections, incorrect setting of crossover switch and gain controls, etc. There is a Power (PWR) & Protection (PRT) LED on the side panel of your KICKER VXA series amplifier. Depending on the state of the amplifier and the vehicle's charging system, the LED will glow either green or red. When the green LED is lit, this indicates the amplifier is turned on and no trouble exists.

Blue LED off, no output? With a Volt Ohm Meter (VOM) check the following: ❶ +12 volt power terminal (should read +12V to +16V) ❷ Remote turn-on terminal (should read +12V to +16V) ❸ Check for reversed power and ground connections ❹ Ground terminal, for proper conductivity.

Blue LED on, no output? Check the following: ❶ RCA connections ❷ Test speaker outputs with a "known" good speaker. ❸ Substitute source unit with a "known" good source unit. ❹ Check for a signal in the RCA cable feeding the amplifier with the VOM meter set to measure "AC" voltage.

Red LED flickering with loud music? The red LED indicates low battery voltage. Check all the connections in your vehicle's charging system. It may be necessary to replace or charge your vehicle's battery or replace your vehicle's alternator.

Red LED on, no output? ❶ Amplifier is very hot = thermal protection is engaged. Test for proper impedance at the speaker terminals with a VOM meter (see the diagrams in this manual for minimum recommended impedance and multiple speaker wiring suggestions). Also check for adequate airflow around the amplifier. ❷ Amplifier shuts down = voltage protection circuitry is engaged. Voltage to the amplifier is not within the 8–16 volt operating range. Have the vehicle's charging and electrical system inspected. ❸ Amplifier will only play at low volume levels = short circuit protection is engaged. Check for speaker wires shorted to each other or to the vehicle chassis. Check for damaged speakers or speaker(s) operating below the minimum recommended impedance.

No or low output? ❶ Check the balance and fader controls on source unit ❷ Check the RCA (or speaker input) and speaker output connections.

Alternator noise-whining sound with engine's RPM? ❶ Check for damaged RCA (or speaker input) cable ❷ Check the routing of RCA (or speaker input) cable ❸ Check the source unit for proper grounding ❹ Check the gain settings and turn them down if they are set too high.

Ground Noise? KICKER amplifiers are engineered to be fully compatible with all manufacturers' head units. Some head units may require additional grounding to prevent noise from entering the audio signal. If you are experiencing this problem with your head unit, in most cases running a ground wire from the RCA outputs on the head unit to the chassis will remedy this issue.

CAUTION: When jump starting the vehicle, be sure that connections made with jumper cables are correct. Improper connections can result in blown amplifier fuses as well as the failure of other critical systems in the vehicle.

If you have more questions about the installation or operation of your new KICKER product, see the Authorized KICKER Dealer where you made your purchase. For more advice on installation, click on the SUPPORT tab on the KICKER homepage, www.kicker.com. Choose the TECHNICAL SUPPORT tab, choose the subject you are interested in, and then download or view the corresponding information. Please E-mail support@kicker.com or call Technical Services (405) 624-8583 for unanswered or specific questions.

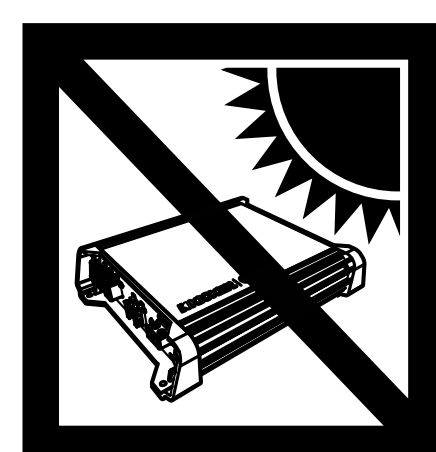

Warranty

When purchased from an Authorized KICKER Dealer, KICKER warrants this product to be free from defects in material and workmanship under normal use for a period of TWO (2) YEARS from date of original purchase with receipt. If this product is identified as “Refurbished” or “B Goods”, the warranty is limited to a period of THREE (3) MONTHS from the date of original purchase. In all cases you must have the original receipt. Should service be necessary under this warranty for any reason due to manufacturing defect or malfunction during the warranty period, KICKER will repair or replace (at its discretion) the defective merchandise with equivalent merchandise. Warranty replacements may have cosmetic scratches and blemishes. Discontinued products may be replaced with more current equivalent products. This warranty is valid only for the original purchaser and is not extended to owners of the product subsequent to the original purchaser. Any applicable implied warranties are limited in duration to a period of the express warranty as provided herein beginning with the date of the original purchase at retail, and no warranties, whether express or implied, shall apply to this product thereafter. Some states do not allow limitations on implied warranties; therefore, these exclusions may not apply to you. This warranty gives you specific legal rights; however you may have other rights that vary from state to state.

WHAT TO DO IF YOU NEED WARRANTY OR SERVICE:

Defective merchandise should be returned to your local Authorized Stillwater Designs (KICKER) Dealer for warranty service. Assistance in locating an Authorized Dealer can be found at www.KICKER.com or by contacting Stillwater Designs directly. You can confirm that a dealer is authorized by asking to see a current authorized dealer window decal.

If it becomes necessary for you to return defective merchandise directly to Stillwater Designs (KICKER), call the KICKER Customer Service Department at (405) 624-8510 for a Return Merchandise Authorization (RMA) number. Package only the defective items in a package that will prevent shipping damage, and return to:

Stillwater Designs
3100 North Husband St
Stillwater, OK 74075

The RMA number must be clearly marked on the outside of the package. Please return only defective components. The return of functioning items increases your return freight charges. Non-defective items will be returned freight collect to you. For example, if a subwoofer is defective, only return the defective subwoofer, not the entire enclosure. Include a copy of the original receipt with the purchase date clearly visible, and a “proof-of-purchase” statement listing the Customer’s name, Dealer’s name and invoice number, and product purchased. Warranty expiration on items without proof-of-purchase will be determined from the type of sale and manufacturing date code. Freight must be prepaid; items sent freight-collect, or COD, will be refused.

WHAT IS NOT COVERED?

This warranty is valid only if the product is used for the purpose for which it was designed. It does not cover:

- o Damage due to improper installation
- o Subsequent damage to other components
- o Damage caused by excessive heat, chemical cleaners, and/or UV radiation
- o Damage through negligence, misuse, accident or abuse. Repeated returns for the same damage may be considered abuse
- o Any cost or expense related to the removal or reinstallation of product
- o Speakers damaged due to amplifier clipping or distortion
- o Items previously repaired or modified by any unauthorized repair facility
- o Return shipping on non-defective items
- o Products with tampered or missing barcode labels
- o Products with tampered or missing serial numbers
- o Products returned without a Return Merchandise Authorization (RMA) number
- o Products purchased from an UNAUTHORIZED dealer
- o Freight Damage
- o The cost of shipping product to KICKER
- o Service performed by anyone other than KICKER

HOW LONG WILL IT TAKE?

KICKER strives to maintain a goal of one week turnaround for all electronics (amplifiers, crossovers, equalizers, etc.) returns. Delays may be incurred if lack of replacement inventory or parts is encountered. Failure to follow these steps may void your warranty. Any questions can be directed to the KICKER Customer Service Department at (405) 624-8510. Contact your International KICKER dealer or distributor concerning specific procedures for your country’s warranty policies.

Garantía | Garantie

Contact your International KICKER dealer or distributor concerning specific procedures for your country's warranty policies.

Our goods come with guarantees that cannot be excluded under the **Australian Consumer Law**. You are entitled to a replacement or refund for a major failure and for compensation for any other reasonably foreseeable loss or damage. You are also entitled to have the goods repaired or replaced if the goods fail to be of acceptable quality and the failure does not amount to a major failure.

GARANTÍA INTERNACIONAL **Versión Español**

Comuníquese con su concesionario o distribuidor KICKER internacional para obtener información sobre procedimientos específicos relacionados con las normas de garantía de su país.

La frase “combustible para vivir la vida Livin’ Loud™ a todo volumen” se refiere al entusiasmo por la vida que la marca KICKER de estéreos de automóvil representa y a la recomendación a nuestros clientes de que vivan lo mejor posible (“a todo volumen”) en todo sentido. La línea de altavoces y amplificadores KICKER es la mejor del mercado de audio de automóviles y por lo tanto representa el “combustible” para vivir a todo volumen en el área de “estéreos de automóvil” de la vida de nuestros clientes. Recomendamos a todos nuestros clientes que obedezcan todas las reglas y reglamentos locales sobre ruido en cuanto a los niveles legales y apropiados de audición fuera del vehículo.

INTERNATIONALE GARANTIE **Deutsche Version**

Nehmen Sie mit Ihren internationalen KICKER-Fachhändler oder Vertrieb Kontakt auf, um Details über die Garantieleistungen in Ihrem Land zu erfahren.

Der Slogan “Treibstoff für Livin’ Loud” bezieht sich auf die mit den KICKER-Autostereosystemen assoziierte Lebensfreude und die Tatsache, dass wir unsere Kunden ermutigen, in allen Aspekten ihres Lebens nach dem Besten (“Livin’ Loud”) zu streben. Die Lautsprecher und Verstärker von KICKER sind auf dem Markt für Auto-Soundsysteme führend und stellen somit den “Treibstoff” für das Autostereoerlebnis unserer Kunden dar. Wir empfehlen allen unseren Kunden, sich bezüglich der zugelassenen und passenden Lautstärkepegel außerhalb des Autos an die örtlichen Lärmvorschriften zu halten.

GARANTIE INTERNATIONALE **Version Française**

Pour connaître les procédures propres à la politique de garantie de votre pays, contactez votre revendeur ou distributeur International KICKER.

L’expression “ carburant pour vivre plein pot “ fait référence au dynamisme de la marque KICKER d’équipements audio pour véhicules et a pour but d’encourager nos clients à faire le maximum (“ vivre plein pot “) dans tous les aspects de leur vie. Les haut-parleurs et amplificateurs KICKER sont les meilleurs dans le domaine des équipements audio et représentent donc pour nos client le “ carburant pour vivre plein pot “ dans l’aspect “ installation audio de véhicule “ de leur vie. Nous encourageons tous nos clients à respecter toutes les lois et réglementations locales relatives aux niveaux sonores acceptables à l’extérieur des véhicules.

P.O. Box 459

Stillwater, Oklahoma 74076

USA

(405) 624-8510

 **stillwaterdesigns**